

CAMBRIDGE S-SERIES

BLOW THRU - DIRECT GAS-FIRED SPACE HEATERS

ENGINEERING SPECIFICATIONS MANUAL

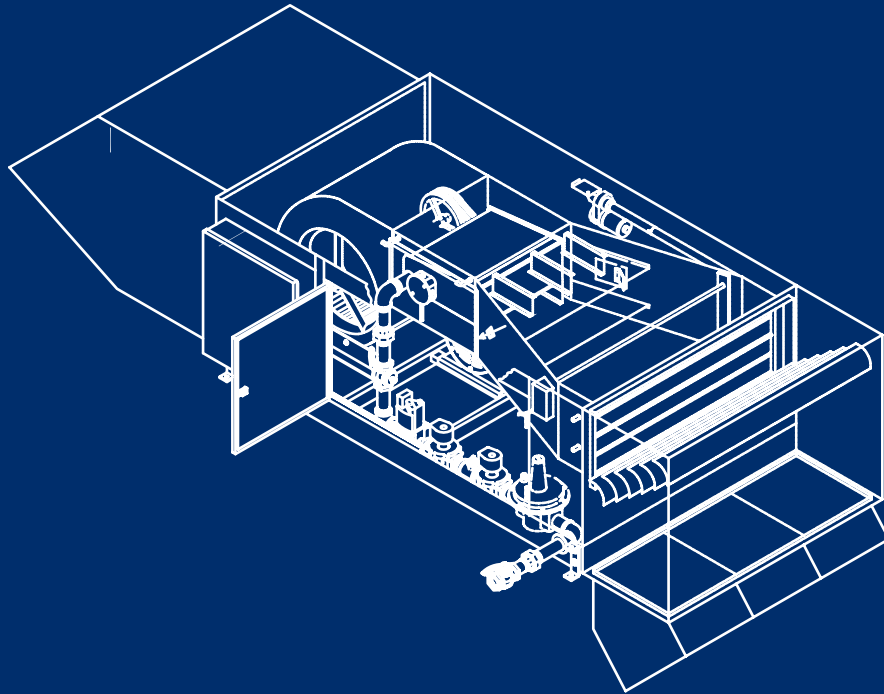

400 to 3,400 MBH Capacities
Complete Heater Packages & Options



760 Long Road Crossing Dr., Chesterfield MO 63005 • (636) 532-2233 • (800) 899-1989 • Fax (636) 530-6133 • www.cambridgeair.com



Being the best at saving energy, reducing operating costs and improving indoor air quality has made Cambridge Air Solutions the preferred choice for heating warehouses, manufacturing plants, automobile service areas, aircraft hangars, indoor recreational facilities and other large commercial/industrial buildings. Cambridge's High Temperature Heating & Ventilation (HTHV) Blow-Thru® Space Heating Technology outperforms every other direct gas-fired heater on the market.

Application

- **Flexible Application** - Cambridge® S-Series HTHV Heaters can be used as a perimeter heating system or rotating air system; and as an air-neutralization or air-pressurization system. When properly applied, Cambridge's HTHV Blow-Thru® Space Heaters will heat the fresh air required to address the facility's air infiltration space heating needs.
- **High Induction Ratio** - The high velocity discharge air induces large volumes of room air into the discharge stream, at a ratio exceeding 10:1. This process mixes the high temperature discharge air with room air, providing large volumes of fresh, warm air flowing throughout the building, thus eliminating higher ceiling temperature and uncomfortable drafts.

Certification

- **Tested and Certified by CSA International** - Cambridge was the first manufacturer certified to the more stringent requirements of ANSI Standard Z83.4/CSA3.7 for non-recirculating air heaters. S-Series Heaters are approved for use in both the U.S. and Canada.
- **ASHRAE 90.1 Compliant** - Properly configured energy efficient Cambridge® HTHV Heaters comply with the latest requirements of ASHRAE Standard 90.1. This is a requirement for LEED Certified Green Buildings and a growing number of local, state and federal (DOE) building codes.
- **Safe** - Non-recirculating Cambridge® HTHV Heaters have less than 5.0 ppm carbon monoxide and 0.5 ppm nitrogen dioxide at all firing rates. S-Series HTHV Heaters use 100% fresh outside air to improve indoor air quality.
- **Max Performance** - Despite misleading claims by our competitors, only Cambridge has a certified heater that will take 0°F inlet air and heat it through a 160°F temperature rise to achieve a max discharge temperature of 160°F. This higher temperature rating is crucial for space heating applications where the cost of energy matters.

Proprietary Cambridge Burner

Cambridge designs and manufactures its own proprietary high efficiency, stainless steel burners. You can't get the high performance and extended life of a Cambridge burner unless you have a Cambridge® HTHV Heater.

Blow-Thru® Space Heater Design

The S-Series HTHV Heater uses Blow-Thru® Space Heating Technology, where the proprietary Cambridge burner is located downstream of the blower. This translates into a smaller, more energy efficient design for space heating applications compared to a conventional draw-thru make-up air heater. Cambridge's S-Series HTHV Heaters use a lower horsepower motor and, most important of all, use less outside air to heat a building. This is because of its higher btu/cfm ratio and unique certified 160°F maximum rating for both discharge temperature and temperature rise from 0°F.

Cambridge Blow-Thru® Heater

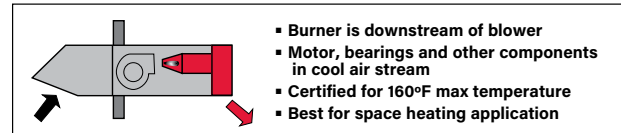

Save Energy

High temperature rise, Blow-Thru® Space Heaters are 40% to 70% more energy efficient than other types of indirect and direct gas-fired systems used to heat/ventilate large commercial and industrial buildings. This has been documented by computer energy modeling and a growing list of over 300 on-site building studies.

Other Industrial Heating Systems	Energy Savings with Cambridge® Space Heaters*
Boilers	40% to 70%
Unit Heaters	30% to 50%
Air Turnover Systems	25% to 70%
Infrared (Radiant)	15% to 40%
Make-Up Air (MUA)	20% to 50%
Recirculation (80/20 - pressurization)	20% to 50%

* Some building studies show more energy savings than listed above

Reduce Carbon Footprint

Saving energy means a corresponding reduction in CO₂ emissions to reduce your building's carbon footprint. Cambridge heaters are recommended for LEED/Green projects.

Lower Installation Costs

Smaller, lightweight, pre-piped and pre-wired S-Series HTHV Heaters are available with five mounting options including the popular thru-wall design for easier installation. Every heater is tested as a fully assembled unit to minimize initial start-up problems.

Reliability

Cambridge® HTHV Heaters require little maintenance and are built to last. The Blow-Thru® design means the motor and other critical components are located in the cool air stream for extended life. Patented Low Fire Start technology increases reliability and saves energy. The industry's best warranty package includes 2 years on the heater and 5 years on the stainless Cambridge burner.

Specifications

S-Series HTHV Blow-Thru Space Heater

General: The high efficiency, S-Series HTHV Direct Gas-Fired Heater shall be manufactured, assembled and factory tested to assure proper alignment of assemblies and performance of controls and other components. Each heater must be design certified by CSA International to be in compliance with ANSI Standard Z83.4 - CSA 3.7 for Non-Recirculating Direct Gas-Fired Industrial Air Heaters and be labeled ASHRAE 90.1 compliant. **Each heater shall be capable of achieving a 160°F temperature rise with a discharge temperature of 160°F at 0°F outdoor temperature in accordance with the terms of the certification.** The standard heater mounting package, including all specified components, shall be thru wall roof top under roof outdoor vertical indoor vertical.

Construction: Each **Blow-Thru** space heater shall be constructed with the **burner section located at the blower discharge**, isolating the blower, motor, drive and control components from operationally detrimental high temperatures. The construction of each heater shall be built around a structurally reinforced, unitized housing and base made of G90 galvanized steel and shall be painted with a gray polyester powder paint finish. **Indoor mounted heaters** are to have a fully insulated cabinet with 1" thick, 1½ lb. density NFPA 90A thermal and acoustical insulation (mechanically fastened). The base of indoor heaters shall be fully, internally insulated with ½" thick, non-water absorbing, closed cell insulation. **Outdoor mounted heaters** shall have watertight access panels to the blower, motor and drive, and gas train. The control enclosure shall be directly accessible from the exterior of the heater and shall be watertight with a full length, continuous stainless steel hinge and full perimeter gasket seal.

Blower: The blower shall be constructed with a discharge transition duct which is approximately 2½ wheel diameters in length to provide maximum regain of static pressure and uniform discharge air temperature. The blower shall be a double width double inlet (DWDI), forward-curved centrifugal fan with a painted housing. The fan wheel shall be statically and dynamically balanced. [The fan bearings on Series S400, S800, S950, S1200 (with 3 HP motors) heaters shall have permanently lubricated self-aligning sealed ball bearings, resiliently mounted for sound and vibration attenuation.] [The fan bearings on Series S1200 (with 5 HP motors), S1600, S1850, S2200, and S3200 heaters shall have self-aligning, sealed ball bearings with grease fittings.] Fan bearings are to be located out of the heated air stream. Fan speed shall be at least 25% below the first critical speed for the shaft. The shaft shall be coated with a rust inhibitor. Bearing slingers shall be provided to minimize airborne moisture access to the fan bearings.

Motor/Drive: The motor shall be a ____ HP, ball bearing type, open drip-proof construction, designed for continuous duty at ____ volt ____ phase 60 Hz, and shall have a 1.15 service factor. The motor bearings shall be located out of the heated air stream. The motor mount is to be on an adjustable sliding base. The fan drive shall be a heavy duty V-belt drive designed for a 1.5 minimum service factor based on motor horsepower.

Burner: The direct gas-fired burner shall be suitable for natural gas propane air. Consult factory for LP gas. The burner shall have stainless steel burner plates with non-clogging orifices. The burner shall produce less than 5 PPM (parts per million) carbon monoxide and 0.5 PPM nitrogen dioxide over its entire firing range. **The burner shall be warranted for five years.** The burner shall be furnished with a low voltage/hot surface ignition system and stainless steel flame rod.

Gas Controls: The temperature control system shall be EDL (Electronic Discharge Local) for all heaters. The EDL temperature control utilizes the Maxitrol Series 14 modulation controls. A gas valve leak test switch shall be provided to permit field verification of the gas tightness of the valve seats for heaters over 400,000 BTU/hr. A high gas pressure switch is required in applications where the gas supply pressure to the heater exceeds 14" WC.

Controls: The heater shall be furnished with factory mounted controls to include low temperature cutout, entering air thermostat, pre-purge timer, patented low fire start control, service switches for blower and burner operation at the heater, non-fused disconnect switch, IEC motor starter with single phase overload protection, redundant gas valves, pressure regulator, electronic temperature controls and a low voltage, class 2 transformer for remote control wiring.

WARNING - DO NOT ATTEMPT TO SUBSTITUTE any direct gas-fired heater incapable of achieving 160°F temperature rise with a discharge temperature of 160°F at 0°F outdoor. The technologies are different. Ability to heat the building will be jeopardized and energy costs will increase.

Typical Capacity Selection
For Standard Mounting Packages³ at sea level

Series	Motor HP	Units without Filter Sections						Units with Filter Sections ²					
		160°F Rise ⁴			140°F Rise ⁴			160°F Rise ⁴			140°F Rise ⁴		
		Input MBH ⁵	Inlet cfm	TESP ¹ "WC	Input MBH ⁵	Inlet cfm	TESP ¹ "WC	Input MBH ⁵	Inlet cfm	TESP ¹ "WC	Input MBH ⁵	Inlet cfm	TESP ¹ "WC
S400	1	400	1,850	.13	400	2,210	.16	400	1,850	.25	400	2,210	.30
S800	3	757	3,500	.39	634	3,500	.39	735	3,400	.72	616	3,400	.72
S950	2	950	4,400	.22	950	5,250	.27	950	4,400	.31	900	4,970	.34
	3										950	5,250	.39
S1200	3	1200	5,555	.26	1064	5,875	.30	1200	5,555	.44	1023	5,650	.45
	5				1200	6,625	.42				1200	6,625	.75
S1600	5	1499	6,940	.50	1257	6,940	.50	1458	6,750	.75	1223	6,750	.75
S1850	5	1850	8,565	.19	1773	9,790	.23	1850	8,565	.25	1757	9,700	.30
	7½				1850	10,215	.24				1850	10,215	.31
S2200	7½	2200	10,185	.21	2065	11,400	.26	2200	10,185	.32	2028	11,200	.40
	10				2200	12,145	.31				2200	12,145	.48
S3200	10	2718	12,585	.36	2279	12,585	.36	2678	12,400	.48	2246	12,400	.48
	15	3107	14,380	.54	2604	14,380	.54	3046	14,100	.84	2554	14,100	.84

¹Total External Static Pressure (TESP) is the total of all airflow resistances (in inches WC) from Mounting Package components. Any other system air flow resistances such as ductwork should be added to the above TESP figures.

²Pressure losses given for air filters in clean condition.

³For Indoor Vertical Mounting Package ratings, consult factory.

⁴The MBH and cfm ratings are based upon a discharge temperature of 160°F.

⁵Heater Input Capacity: $Btu/hr = cfm \times \rho \times c_p \times 60 \times \Delta T \div 0.92$

Where: **cfm** is the inlet air volume of the blower
ρ is the density⁶ of the air handled by the blower (lb/ft³)
c_p is the specific heat of the air (0.240 Btu/lb °F)
60 is the conversion from minutes to hours
ΔT is the temperature rise (160°F Max.)
0.92 is the conversion from sensible to total heat (output to input)

⁶Density is calculated from the following formula: $\rho = 1.32605 \times (\text{barometric pressure} \div ^\circ R)$

Where: barometric pressure is in terms of inches of mercury ("Hg) and °R = (460 + T_{inlet} °F)

Series	Gas Inlet Size	Supply Pressure ⁸ Capacities - Natural Gas ⁹ (MBH)									
		6"WC	7"WC	8"WC	9"WC	10"WC	11"WC	12"WC	13"WC	14"WC	
S400	¾"	390	400								
S800	1"	485	535	585	630	665	705	745	780	800	
S950	1"	740	810	890	950						
S1200	1¼"	900	990	1060	1190	1200					
S1600	1¼"	990	1100	1230	1310	1400	1480	1550	1600		
S1850	1½"	1380	1540	1720	1830	1850					
S2200	1½"	1500	1660	1830	2020	2200					
S3200	1½" ⁷	1660	1960	2200	2420	2600	2800	3000	3140	3200	

⁷On S3200 heaters with Gas Supply Pressure below 1 psi or over 5 psi with a high pressure regulator, the inlet pipe size is increased to 2".

⁸Positive shut-off pressure regulators are required when gas supply pressure exceeds 14" WC for Series S400; 1 psi for Series S800, S950 and S1200; 2 psi for Series S1600; and 5 psi for Series S1850, S2200 and S3200.

⁹Consult factory for LP gas requirements.

Thru Wall (TW)

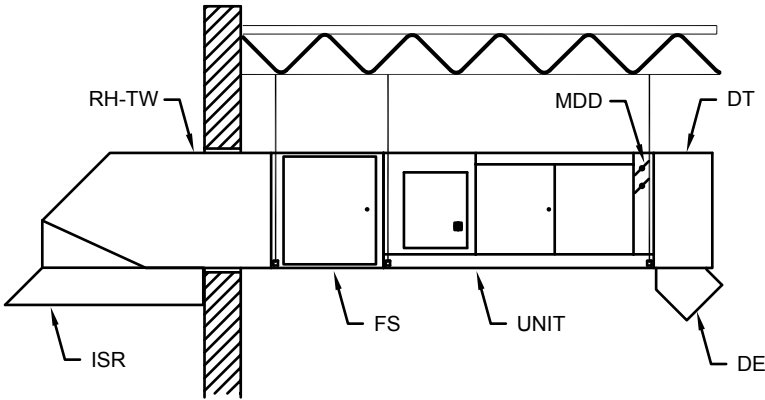

Outdoor Vertical

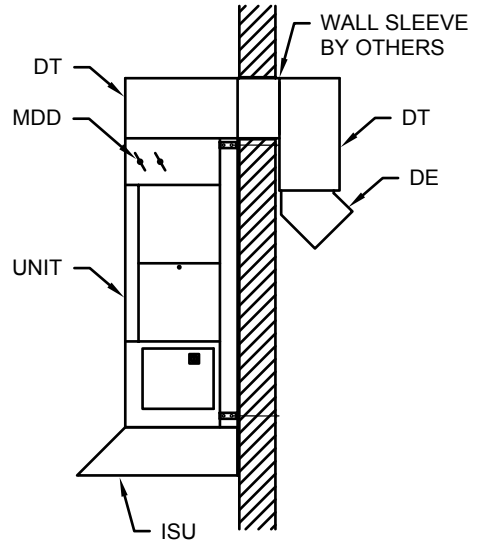

Roof Top (RT)

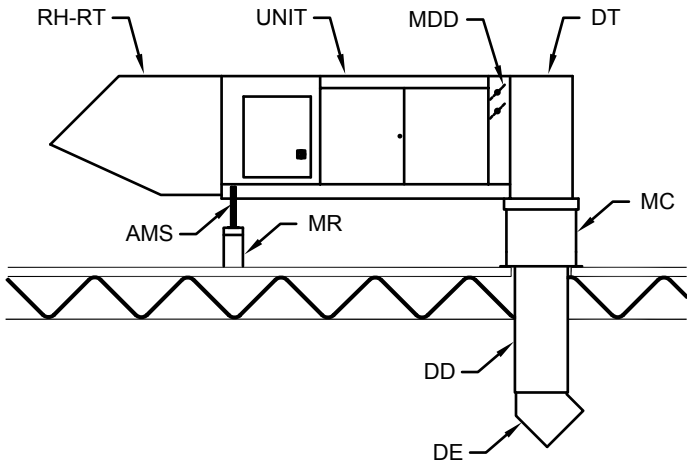

Indoor Vertical

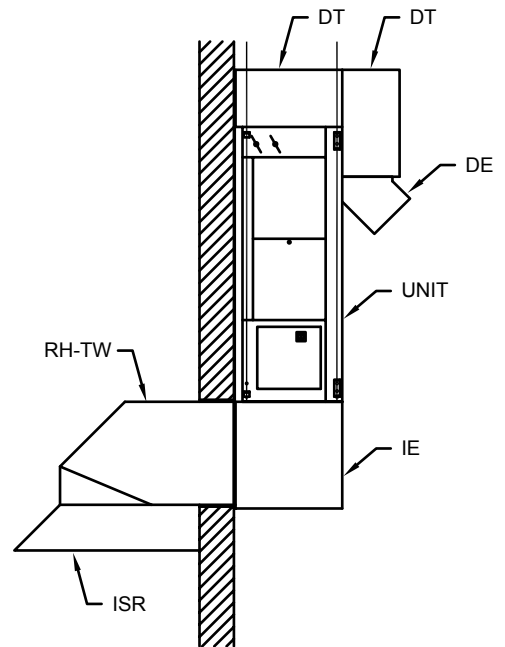

Under Roof

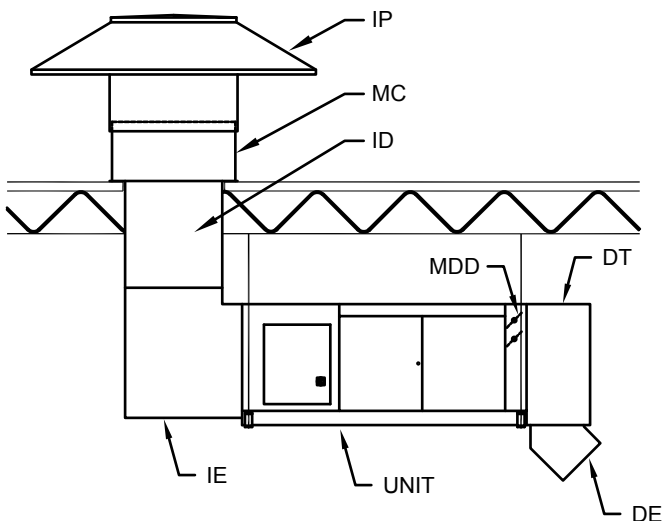

DD	Discharge Duct: The 50" discharge duct for roof top mounting package extends through the mounting curb.
DE	Directional Elbows¹: Used to optimize heat distribution by directing air to meet the requirements of specific field applications. Field mounting is required.
DISC	Non-Fused Disconnect¹: Service Switch for main power to the heater. Interlocked with the door of the electrical control enclosure.
DT	Downturn¹: A 90° elbow with turning vanes. Thermal/acoustical insulation is factory installed.
EAT	Entering Air Thermostat¹: The EAT automatically turns off the burner when the outdoor temperature approaches the EAT setpoint temperature (45°F to 70°F) while maintaining blower operation for ventilation.
EDL	Electronic Discharge Local Gas Trains¹: An electronic discharge air temperature control which utilizes a discharge temperature sensor in conjunction with an electronic proportioning gas valve for maintaining the selected discharge air temperature. This control will permit manual adjustment of the discharge air temperature from 110°F to 160°F via the selector on the amplifier located in the heater's electrical control enclosure. (Field mounted external to vertical units except S400.)
IE	Inlet Elbow: Equipped with turning vanes, is used in conjunction with the under roof and the indoor vertical mounting option. Internally insulated bottom with non-water absorbing, closed cell insulation.
IPP	Inlet Plenum Package²: Used for the under roof mounting package, which consists of the inlet plenum, insulated 12" or 24" IPP mounting curb, and insulated inlet duct, 38" or 50" long. Filters are optional. Cant by others.
ISR	Inlet Skirt - Rain Hood: Used on the thru wall mounting package in conjunction with the thru wall rain hood. The accessory is recommended for applications subject to snow conditions. Field assembly is required.
ISU	Inlet Skirt - Unit: Required for outdoor vertical mounting package. Field assembly is required.
LFS	Low Fire Start¹: The LFS function limits the initial heater firing for the first fifteen seconds of a heating cycle.
LTC	Low Temperature Cutout with Alarm¹: The LTC alarm circuit functions to shut down the blower in approximately four (4) minutes if either of the following occurs: (1) The inlet temperature drops below the LTC setpoint (40, 45, 50 or 55°F) in the Ventilation mode; or (2) The gas valve fails to remain energized during a heating cycle.
MB	Mounting Brackets¹: Provided on the vertical and horizontal heaters for installation from hanging rods.
MC	Mounting Curb: The insulated 24" mounting curb supports the discharge end of the unit and mates to the downturn. This mounting curb is designed for conventional, flat roof applications. Counter flashing is included. A cant, if required, is provided by others.
MDD	Motorized Discharge Damper¹: An internally mounted two-position damper assembly that closes when the blower is not operating. Factory installed.
MR/AMS	Mounting Rail/Mounting Stand: An adjustable mounting stand (6 ³ / ₄ " to 14 ¹ / ₄ ") is used in conjunction with the mounting rail as the rear heater support on the roof top mounting package. The rail provides a roof interface for both rubber and built-up roof decks. A counter flashing is provided. A cant, if required, is provided by others. An additional mounting stand and mounting rail is required when a filter section is specified. A 1 ¹ / ₂ " thick piece of pressure treated wood is required (not provided) for the base of the stand to rest on to meet the overall height of 24".
PT	Pre-Purge Timer¹: The PT function provides a minimum of four air changes in the heater housing and any attached inlet accessories or field installed ductwork prior to an ignition attempt. The time is selectable at 2, 4, 8, 16, or 32 seconds.
RCS-S	Remote Control Station-Security¹: The RCS-S is a lockable NEMA 1 enclosure (9"w x 14"h x 5"d) equipped with a three position keylock selector switch (Summer Ventilation - Off - Heating), an operating electronic thermostat (OET), and indicating lights for blower operation (green), burner operation (red), and reset (amber).
RH-RT	Rain Hood - Roof Top²: For the roof top mounting package; provided with an expanded metal inlet screen.
RH-TW	Rain Hood - Thru Wall²: For thru wall mounting package; provided with an expanded metal inlet screen. The thru wall rain hood length includes an integral insulated collar to accommodate up to 21" thick walls.
SS	Service Switches¹: Located in the heater to allow local control by Service Technician when servicing the heater.

¹ Included with all Standard Mounting Packages shown on page 6.

² If one of the noted inlet accessories is not ordered, an inlet screen will be provided.

Unit Weights and Dimensions

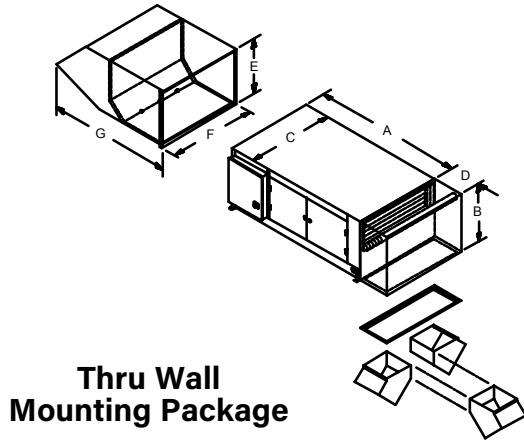

Thru Wall Mounting Package

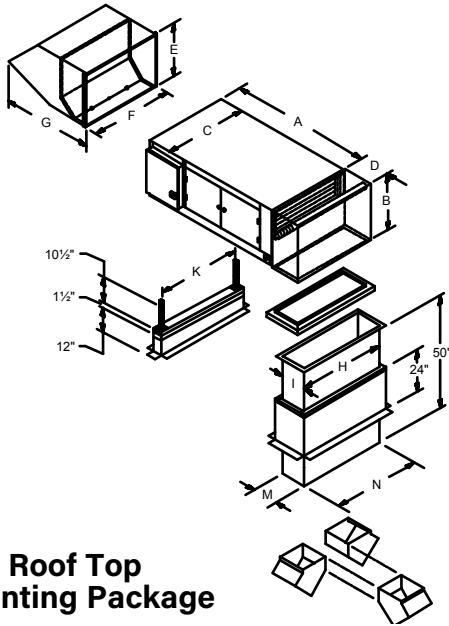

Roof Top Mounting Package

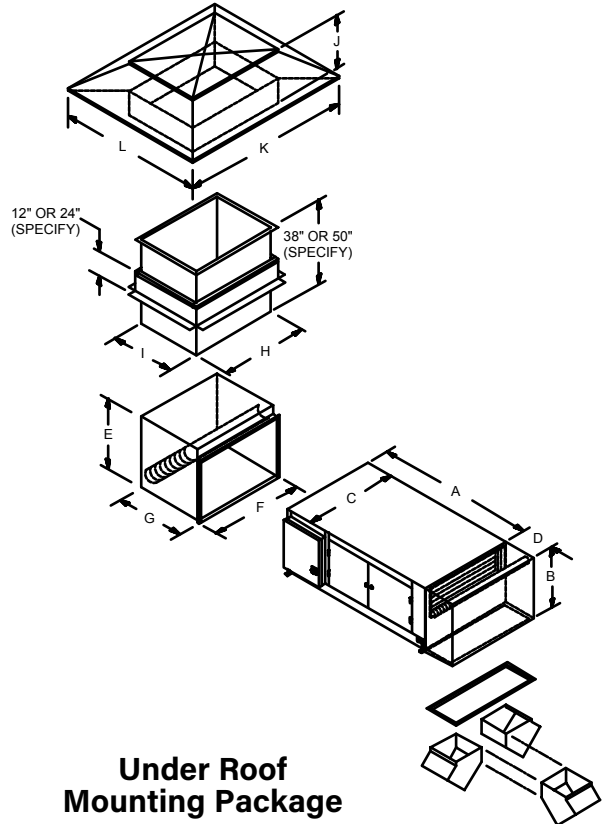

Under Roof Mounting Package

Mounting Package	Series	Dimensions														Weight (lbs.)
		A	B	C	D	E	F	G	H	I	J	K	L	M	N	
Thru Wall	S400/800	60"	25½"	25½"	13"	24"	23½"	57¾"								550
	S950/1200/1600	72"	28"	42"	15"	27"	40¼"	60"								800
	S1850/2200/3200	80"	37½"	47"	24¾"	36¾"	45¼"	72"								1500
Roof Top	S400/800	60"	25½"	25½"	13"	24"	23½"	36¾"	22¼"	11"		25½"		11"	22¼"	600
	S950	72"	28"	42"	15"	27"	40¼"	39"	39½"	13"		42"		11"	33⅜"	900
	S1200/1600	72"	28"	42"	15"	27"	40¼"	39"	39½"	13"		42"		13"	39½"	900
	S1850	80"	37½"	47"	24¾"	36¾"	45¼"	51"	44¾"	22¼"		47"		22¼"	33⅜"	1650
	S2200/3200	80"	37½"	47"	24¾"	36¾"	45¼"	51"	44¾"	22¼"		47"		22¼"	44¾"	1650
Under Roof	S400/800	60"	25½"	25½"	13"	27½"	23¼"	26½"	23"	23"	24"	60"	60"			750
	S950/1200/1600	72"	28"	42"	15"	30¼"	39½"	31¼"	39½"	28"	24"	76¼"	65½"			1150
	S1850/2200/3200	80"	37½"	47"	24¾"	40"	45¼"	38½"	45"	35½"	32"	90"	80½"			1900

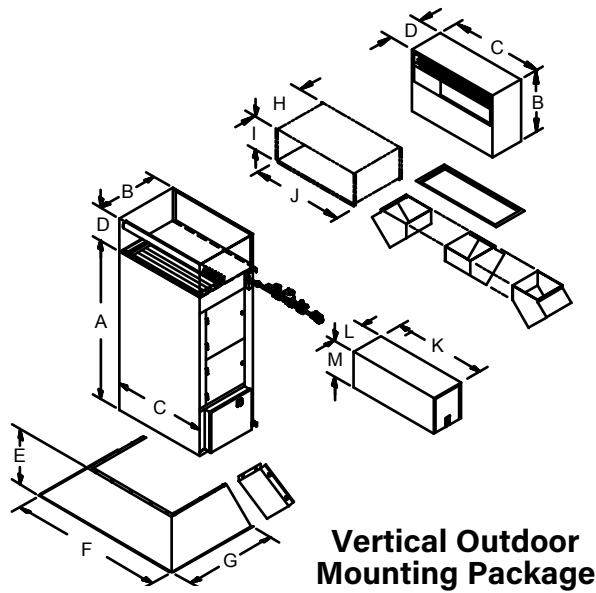

Vertical Outdoor Mounting Package

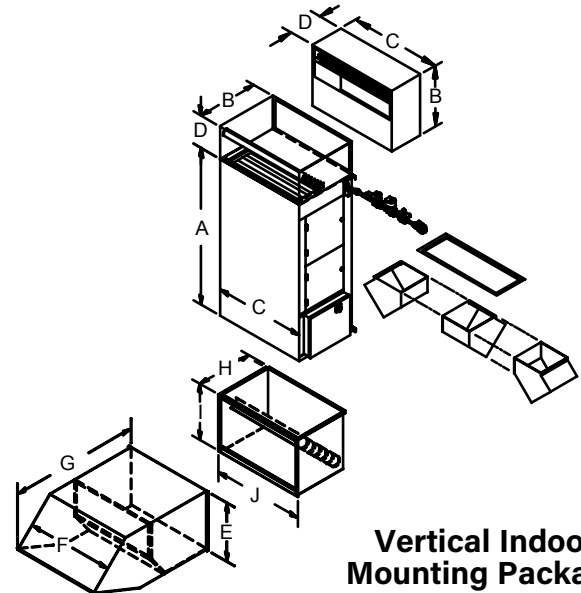

Vertical Indoor Mounting Package

Mounting Package	Series	Dimensions													Weight (lbs.)
		A	B	C	D	E	F	G	H	I	J	K	L	M	
Vertical Outdoor	S400/800	60"	25½"	25½"	13"	12"	49½"	37¾"	(A)	11"	22¼"	34"	14"	16"	500
	S950/1200/1600	72"	28"	42"	15"	12"	66"	40"	(A)	13"	39½"	34"	14"	16"	750
	S1850/2200	80"	37½"	47"	24¾"	12"	71"	49"	(A)	22¼"	44¾"	34"	14"	16"	1500
	S3200	80"	37½"	47"	24¾"	12"	71"	49"	(A)	22¼"	44¾"	42"	18"	26"	1500
Vertical Indoor	S400/800	60"	25½"	25½"	13"	24"	23½"	57¾"	25½"	25½"	25½"				650
	S950/1200/1600	72"	28"	42"	15"	27"	40¼"	60"	28"	28"	42"				950
	S1850/2200/3200	80"	37½"	47"	24¾"	36¾"	45¼"	72"	37½"	37½"	47"				1750

A = To be determined at installation

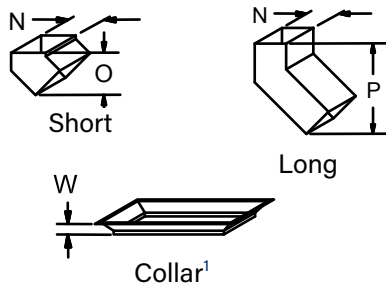

Directional Elbows

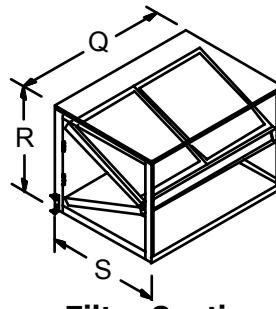

Filter Section (optional)

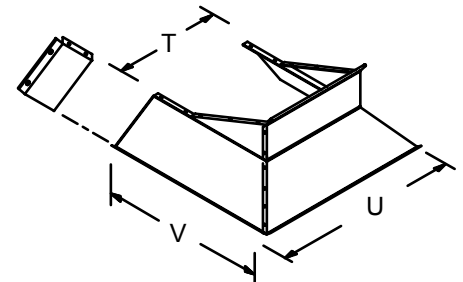

Inlet Skirt for Rain Hood (optional)

Series	Directional Elbows						Filter Section				Inlet Skirt for Rain Hood			
	Dimensions				Quantity		Dimensions			Weight (lbs.)	Dimensions			Weight (lbs.)
	N	O	P	W ¹	Short	Long	Q	R	S		T	U	V	
S400/800	11¼"	13¾"			2		25½"	25½"	33"	67	23½"	47½"	46½"	39
S950	11¼"	13¾"		3"	3		42"	28"	33"	90	40¼"	64¼"	49¾"	42
S1200/1600	13¼"	15"			3		42"	28"	33"	90	40¼"	64¼"	49¾"	42
S1850	11¼"	13¾"	21½"	5"	3	3	47"	37½"	35½"	130	45¼"	69¼"	60¾"	50
S2200/3200	11¼"	13¾"	21½"		4	4	47"	37½"	35½"	130	45¼"	69¼"	60¾"	50

¹Does not apply to Roof Top applications

S-Series Selection

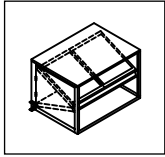

Filter Section (FS)

The FS is an in-line, V-bank filter section with 2" Permanent or Throw-away filters. The Filter Section is attached directly to the inlet end of the heater, with any additional inlet accessories attached directly to the inlet end of filter section. Each S-Series heater has the following number of filters in each filter section:

Series	Quantity	Dimensions
S400/S800	2	20" x 25" x 2"
S950/S1200/S1600	4	20" x 25" x 2"
S1850/S2200/S3200	12	16" x 25" x 2"

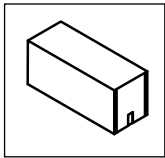

Gas Train Enclosure (GTE)

The GTE is provided on all outdoor applications which require external mounting of gas train components. The following applications normally require this accessory:

- All vertical units over 400 MBH
- FM applications with filter sections or without a discharge damper

Electrical Control Options

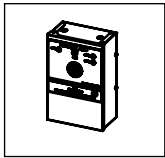

Temperature Setback System (TSS)

The TSS is a lockable NEMA 1 enclosure (9"w x 14"h x 5"d) equipped with a three position keylock selector switch (Summer Ventilation - Off - Heating), a combination operating electronic thermostat and seven day programmable time clock, an override timer and indicating lights for blower operation (green), burner operation (red) and reset (amber). The TSS accommodates separate programming for summer ventilation and heating modes.

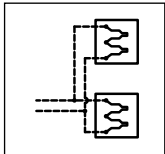

Temperature Averaging System (TAS-2)

The TAS-2 option is used in conjunction with the OET or TSS to average the space temperature between two points within a facility. It consists of four thermistors which are wired in a series parallel combination in order to simulate a single thermistor response.

BACnet Controller

Factory provided BACnet MS/TP controller to monitor and control the heater. Provides status of blower, burner and alarms. Controls blower operation and gas modulation for selectable operating modes.

Fused Disconnect Switch (FDS)

The FDS provides for line fusing of power supply voltage.

Exhaust Fan Interlock (EFI)

Terminals are provided for wiring of EFI contacts provided by others. Typically used when the heater shall come on when an exhaust fan comes on.

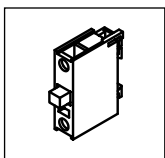

Exhaust Fan Contact (EFC)

The EFC is an auxiliary dry contact mechanically interlocked to the operation of the motor starter of the heater. The dry contact is typically wired into an exhaust fan control circuit to activate an exhaust fan.

Fire Protection Interlock (FPI)

Terminals are provided for wiring of FPI contacts provided by others. Typically used when the heater is required to be disabled by the fire protection system.

High Pressure Regulator (HPR)

A positive shut-off high pressure regulator is required when the gas supply pressure exceeds the maximum gas pressure requirements or is specified by local codes or utilities. It is sized according to the gas supply pressure and the capacity requirements of the heater. It must be vented to the outdoors. (Specify gas supply pressure.)

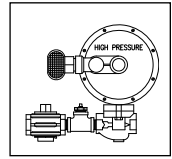

Electronic Discharge Space Modulation (EDSM)

The EDSM temperature control utilizes the Maxitrol Series 44 modulation controls to maintain a constant space temperature (adjustable from 40° to 80°F). Discharge temperature modulates between the minimum (adjustable from 40° to 80°F) and maximum (adjustable from 80° to 160°F) setpoints on the amplifier. Includes an adjustable space temperature control and sensor.

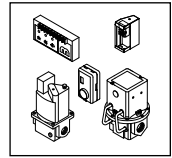

Electronic Discharge Space Modulation / Tamper Proof (EDSM/TP)

The EDSM/TP temperature control is similar to the EDSM temperature control system above except the adjustable space temperature control is mounted in the Remote Control Station and the non-adjustable sensor is mounted in the space.

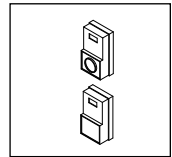

Electronic Discharge Remote (EDR)

The EDR temperature control utilizes the Maxitrol Series 14 modulation controls to maintain the pre-selected discharge temperature that is set on the Remote Heat Adjust control which is mounted in either the Remote Control Station or the heater’s Electrical Control Enclosure.

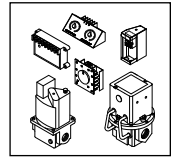

Electronic Discharge Signal Conditioner (EDSC)

The EDSC temperature control utilizes the Maxitrol Series SC controls to maintain a constant temperature rise based on analog input signal from BACnet controller or remote source. Requires external loop control to maintain constant discharge or space temperature. Includes maximum and minimum discharge air temperature limits and low fire start.

Insurance Controls

Controls and gas train to comply with the requirements of Factory Mutual (FM) and/ or Industrial Risk Insurers (IRI). Specify heater input and insurer for proper selection of insurance controls.

Summary of Limited Warranty

Cambridge Air Solutions warrants all S-Series products, including all components and sub-components thereof, to be free from defects in material and workmanship for a period of **twenty-four (24) months** from date of shipment, with the exception of the burner which is warranted for **five (5) years**, provided the product is properly installed and operated under normal conditions in accordance with the Cambridge Technical Manual and any other applicable instructions and in conformance with national and local codes.

For complete warranty, see Standard Terms and Conditions in the product catalog or the Technical Manual.

Wiring Diagram

For EDL gas controls over 400 MBH only
(Refer to Tech Manual for other Gas Control Wiring)

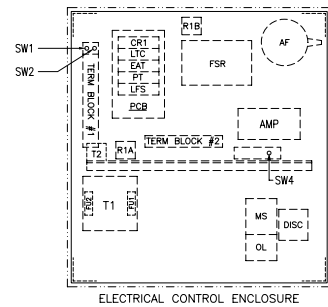
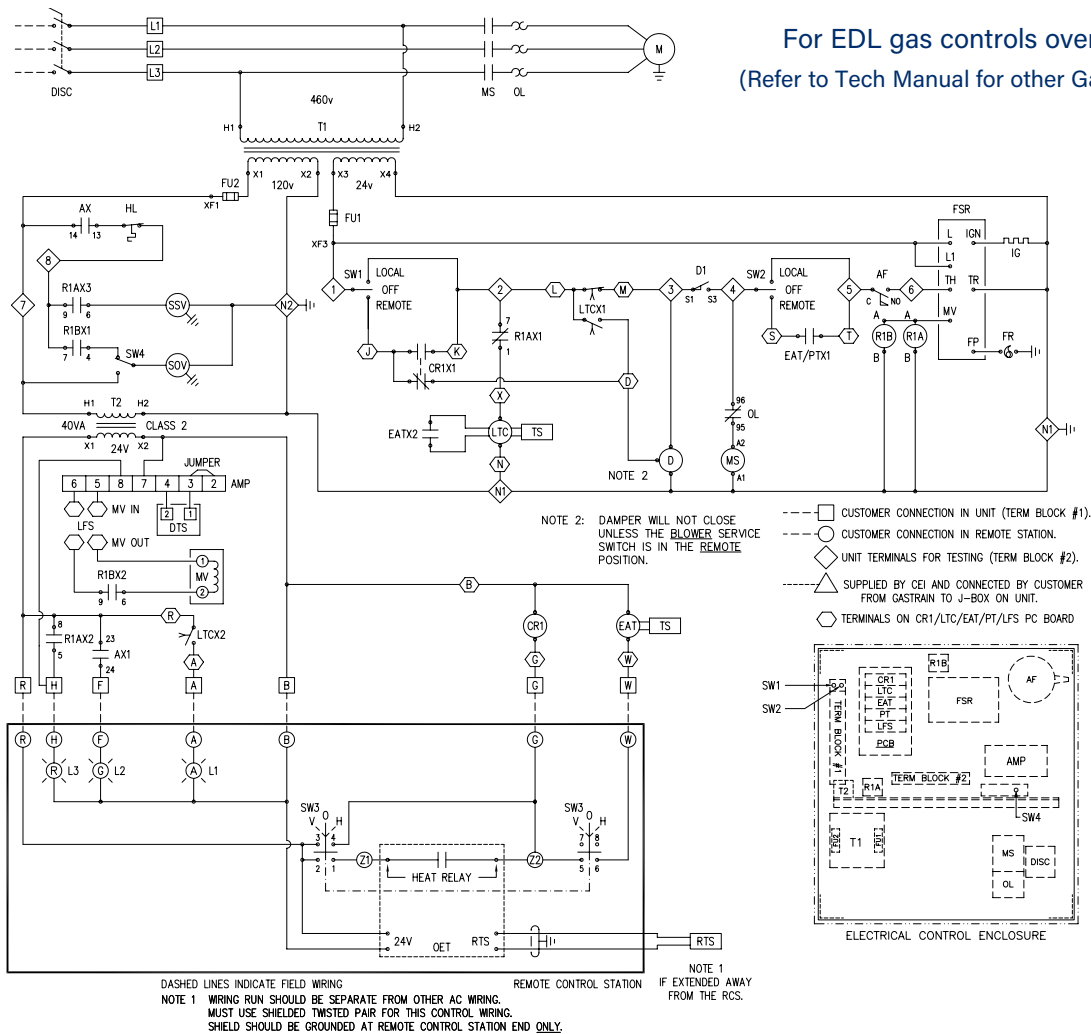

Symbol	Description
AF	Air Flow Switch
AMP	Amplifier Solid State
AX	Auxiliary Contact
AX1	Auxiliary Contact
CR1	Control Relay
D & D1	Damper Motor & End Switch
DISC	Service Disconnect Non - Fused
DTS	Discharge Temperature Sensor
EAT	Entering Air Thermostat
FR	Flame Rod
FSR	Flame Safeguard Relay (HSI)
FU1	Fuse 24 Volt Control

Symbol	Description
FU2	Fuse 120 Volt Control
HL	High Limit
IG	Igniter
L1	Light - Alarm
L2	Light - Fan
L3	Light - Heat
LFS	Low Fire Start
LTC	Low Temperature Cutout
M	Motor
MS	Motor Starter
MV	Modulating Valve
OET	Operating Electronic Thermostat

Symbol	Description
OL	Overload Relay
RTS	Remote Temperature Sensor
R1A&B	Relay Gas Valve
SOV	Shut-Off Valve - Gas
SSV	Safety Shut-Off Valve - Gas
SW1	Service Switch - Fan
SW2	Service Switch - Heat
SW3	Switch - Fan/Off/Heat
SW4	Switch - SOV Leak Test
T1	Transformer (24 & 120 Volt)
T2	Class 2 Transformer (24 Volt)
TS	Temperature Sensor (LTC/ EAT)

Motor Size	Heater Amperage Requirements						
	120V/1Ph	208V/1Ph	230V/1Ph	208V/3Ph	230V/3Ph	460V/3Ph	575V/3Ph
1HP	18.6	9.8	9.3	6.0	5.5	2.8	2.2
2HP	26.6	14.6	13.3	8.9	8.1	4.1	3.2
3HP	36.6	20.1	18.3	12.0	10.9	5.5	4.4
5HP		32.2	29.3	18.1	16.5	8.3	6.6
7½HP				25.6	23.3	11.7	9.5
10HP				32.2	29.3	14.7	11.5
15HP				47.6	43.3	21.7	17.5