

CAMBRIDGE SA-SERIES

BLOW THRU - DIRECT GAS-FIRED SPACE HEATERS

ENGINEERING SPECIFICATIONS MANUAL

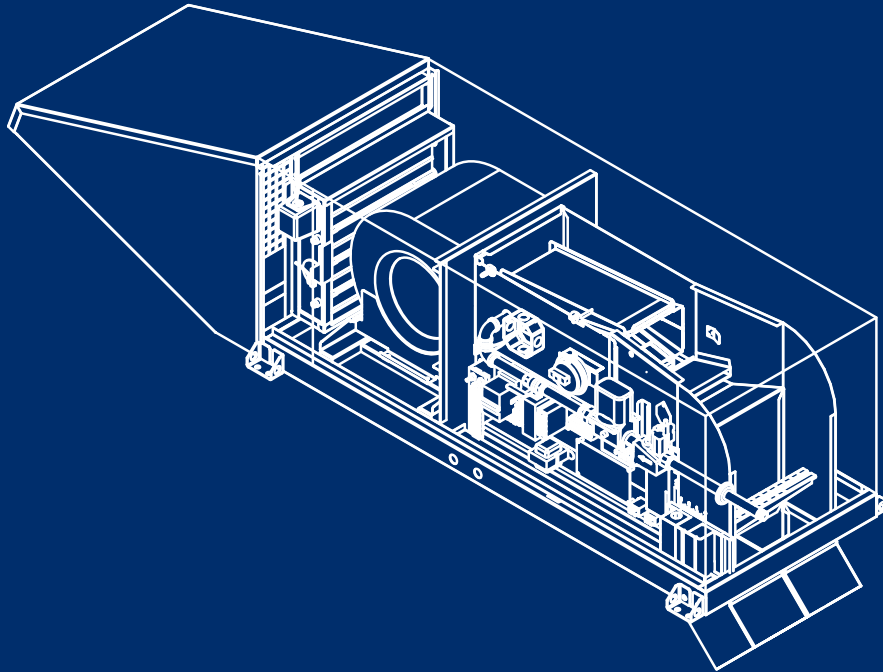

250 MBH Capacities
Complete Heater Packages & Options



760 Long Road Crossing Dr., Chesterfield MO 63005 • (636) 532-2233 • (800) 899-1989 • Fax (636) 530-6133 • www.cambridgeair.com



Being the best at saving energy, reducing operating costs and improving indoor air quality has made Cambridge Air Solutions the preferred choice for heating warehouses, manufacturing plants, automobile service areas, aircraft hangars, indoor recreational facilities, and other commercial/industrial buildings. Other manufacturers now describe their heaters as being "Just Like Cambridge®." Don't believe it! Only Cambridge offers Blow-Thru® Space Heating Technology that outperforms every other direct gas-fired heater on the market.

Application

- **Flexible Application** - Cambridge® SA-Series Heaters can be used as a perimeter heating system or rotating air system; and as an air-neutralization or air-pressurization system. When properly applied, Cambridge Blow-Thru® Space Heaters will heat the least amount of fresh air required to address the facility's air infiltration, make-up air and space heating needs.
- **High Induction Ratio** - The high velocity discharge air induces large volumes of room air into the discharge stream, at a ratio exceeding 10:1. This process mixes the high temperature discharge air with room air, providing large volumes of fresh, warm air flowing throughout the building, thus eliminating higher ceiling temperature and uncomfortable drafts.

Certification

- **Tested and Certified by CSA International** - Cambridge is certified to the stringent requirements of ANSI Standard Z83.4/CSA3.7 for non-recirculating air heaters. SA-Series Heaters are approved for use in both the U.S. and Canada.
- **ASHRAE 90.1 Compliant** - Properly configured energy efficient Cambridge® Heaters comply with the latest requirements of ASHRAE Standard 90.1. This is a requirement for LEED Certified Green Buildings and a growing number of local, state and federal (DOE) building codes.
- **Safe** - Non-recirculating Cambridge® Heaters have less than 5.0 ppm carbon monoxide and 0.5 ppm nitrogen dioxide at all firing rates. SA-Series Heaters use 100% fresh outside air to improve indoor air quality.
- **Max Performance** - Cambridge SA-Series heaters are certified for 160°F maximum discharge temperature, the highest allowed by the standard. This higher discharge temperature rating is crucial for space heating applications where the cost of energy matters.

Proprietary Cambridge Burner

Cambridge designs and manufactures its own proprietary high efficiency, stainless steel burners. You can't get the high performance and extended life of a Cambridge burner unless you have a Cambridge® Heater.

Blow-Thru® Space Heater Design

The SA-Series Heater uses Blow-Thru® Space Heating Technology, where the proprietary Cambridge burner is located downstream of the blower. This translates into a smaller, more energy efficient design for space heating applications compared to a conventional draw-thru make-up air heater. Cambridge® SA-Series Heaters use a lower horsepower motor and, most important of all, use less outside air to heat a building. This is because of its higher Btu/cfm ratio and unique certified 160°F maximum rating for discharge temperature.

Cambridge Blow-Thru® Heater

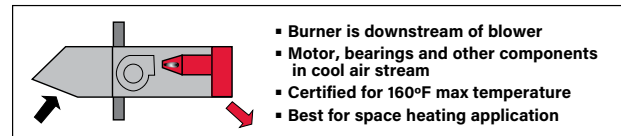

Save Energy

High temperature rise, Blow-Thru® Space Heaters are 40% to 70% more energy efficient than all other types of indirect and direct gas-fired systems used to heat/ventilate large commercial and industrial buildings. This has been documented by computer energy modeling and a growing list of over 300 on-site building studies.

Other Industrial Heating Systems	Energy Savings with Cambridge® Space Heaters*
Boilers	40% to 70%
Unit Heaters	30% to 50%
Air Turnover Systems	25% to 70%
Infrared (Radiant)	15% to 40%
Make-Up Air (MUA)	20% to 50%
Recirculation (80/20 - pressurization)	20% to 50%

* Some building studies show more energy savings than listed above

Reduce Carbon Footprint

Saving energy means a corresponding reduction in CO2 emissions to reduce your building's carbon footprint. Cambridge heaters are recommended for LEED/Green projects.

Lower Installation Costs

Smaller, lightweight, pre-piped and pre-wired SA-Series Heaters are available with three mounting options including the popular thru-wall design for easier installation. Every heater is tested as a fully assembled unit to minimize initial start-up problems.

Reliability

Genuine Cambridge® Heaters require little maintenance and are built to last. The Blow-Thru® design means the motor and other critical components are located in the cool air stream for extended life. Patented Low Fire Start technology increases reliability and saves energy. The industry's best warranty package includes 2 years on the heater and 5 years on the stainless Cambridge burner.

Specifications

SA-Series HTHV Blow-Thru Space Heater

General: The high efficiency, SA-Series Direct Gas-Fired Heater shall be manufactured, assembled and factory tested to assure proper alignment of assemblies and performance of controls and other components. Each heater must be design certified by CSA International to be in compliance with ANSI Standard Z83.4 - CSA 3.7 for Non-Recirculating Direct Gas-Fired Industrial Air Heaters and be labeled ASHRAE 90.1 compliant. Controls and gas train comply with the requirements of Factory Mutual (FM) and XL Insurance Global Asset Protection Services (XL GAPS). **Each heater shall be capable of achieving a 160°F discharge temperature in accordance with the terms of the certification.** The standard heater mounting package, including all specified components, shall be thru wall roof top under roof.

Construction: Each **Blow-Thru** space heater shall be constructed with the **burner section located at the blower discharge**, isolating the blower, motor, drive and control components from operationally detrimental high temperatures. The construction of each heater shall be built around a structurally reinforced, unitized housing and base made of G90 galvanized steel and shall be painted with a gray polyester powder paint finish. **Heaters** are to have a fully insulated cabinet with 1" thick, 1½ lb. density NFPA 90A thermal and acoustical insulation (mechanically fastened). The base of the heaters shall be fully, internally insulated with ½" thick, non-water absorbing, closed cell insulation. The control enclosure shall be directly accessible from the exterior of the heater and shall be watertight with a full perimeter gasket seal.

Blower: The blower shall be constructed with a discharge transition duct which is approximately 2½ wheel diameters in length to provide maximum regain of static pressure and uniform discharge air temperature. The blower shall be a double width double inlet (DWDI), forward-curved centrifugal fan. Fan bearings are to be located out of the heated air stream. Fan speed shall be at least 25% below the first critical speed for the shaft. The shaft shall be coated with a rust inhibitor.

Motor/Drive: The motor shall be a ¾ HP [SA250], ball bearing type, open drip-proof construction, designed for continuous duty at 115 volt [SA250] 1 phase 60 Hz, and shall have a 1.15 service factor. The motor bearings shall be located out of the heated air stream. The fan drive shall be direct drive [SA250].

Burner: The direct gas-fired burner shall be suitable for natural gas. The burner shall have stainless steel burner plates with non-clogging orifices. The burner shall produce less than 5 PPM (parts per million) carbon monoxide and 0.5 PPM nitrogen dioxide over its entire firing range. **The burner shall be warranted for five years.** The burner shall be furnished with a low voltage/hot surface ignition system and stainless steel flame rod.

Gas Controls: The temperature control system shall be Maxitrol Series 44 modulation controls.

Controls: The heater shall be furnished with factory mounted controls to include low temperature cutout, entering air thermostat, pre-purge timer, patented low fire start control, service switches for blower and burner operation at the heater, IEC motor starter with integral motor protection [SA250], redundant gas valves, pressure regulator, electronic temperature controls and a low voltage, class 2 transformer for remote control thermostat wiring.

WARNING - DO NOT ATTEMPT TO SUBSTITUTE any direct gas-fired heater incapable of achieving 160°F discharge temperature. The technologies are different. Ability to heat the building will be jeopardized and energy costs will increase.

Model	Typical Heater Discharge Height ¹ (ft.)
SA250	10 - 15

NOTE: Consider accessibility and safety when selecting discharge height and mounting options.

¹Distance from bottom of discharge to finished floor.

Typical Capacity Selection For Standard Mounting Packages at sea level													
Model	Motor HP	Gas Supply			Roof Top			Thru Wall			Under Roof		
		Inlet Size	Min. Pressure "WC	Max. Pressure "WC	Input MBH ³	Inlet cfm	TESP ² "WC	Input MBH ³	Inlet cfm	TESP ² "WC	Input MBH ³	Inlet cfm	TESP ² "WC
SA250	¾	½"	7	14	250	1,200	.06	250	1,200	.05	250	1,200	.07

²Total External Static Pressure (TESP) is the total of all airflow resistances (in inches WC) from Mounting Package components. Any other system air flow resistances such as ductwork should be added to the above TESP figures.

³The MBH and cfm ratings are based upon an inlet temperature of -40°F.

Heater Input Capacity: $\text{Btu/hr} = \text{cfm} \times \rho \times c_p \times 60 \times \Delta T \div 0.92$

Where: **cfm** is the inlet air volume of the blower
ρ is the density⁴ of the air handled by the blower (lb/ft³)
c_p is the specific heat of the air (0.240 Btu/lb °F)
60 is the conversion from minutes to hours
ΔT is the temperature rise (160°F Max.)
0.92 is the conversion from sensible to total heat (output to input)

⁴Density is calculated from the following formula: $\rho = 1.32605 \times (\text{barometric pressure} \div \text{°R})$

Where: barometric pressure is in terms of inches of mercury ("Hg) and °R = (460 + T_{inlet} °F)

⁵Positive shut-off pressure regulators are required when gas supply pressure exceeds 14" WC

⁶The SA350 was discontinued in 2022.

Standard Mounting Packages

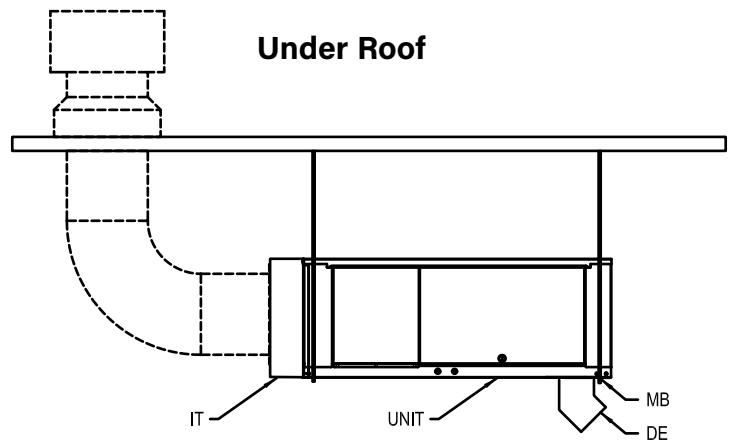
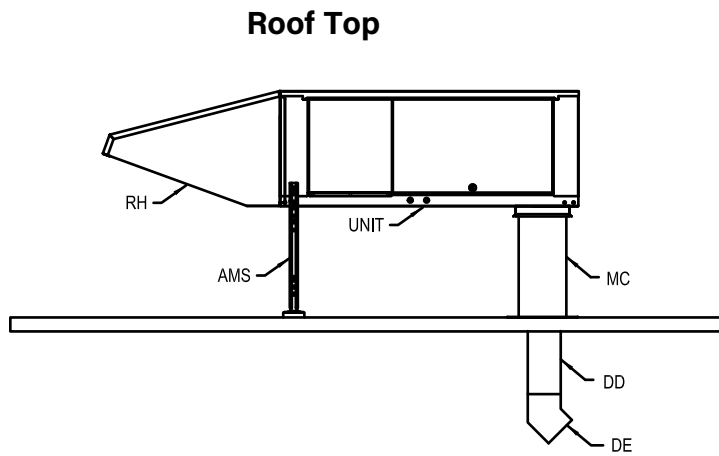
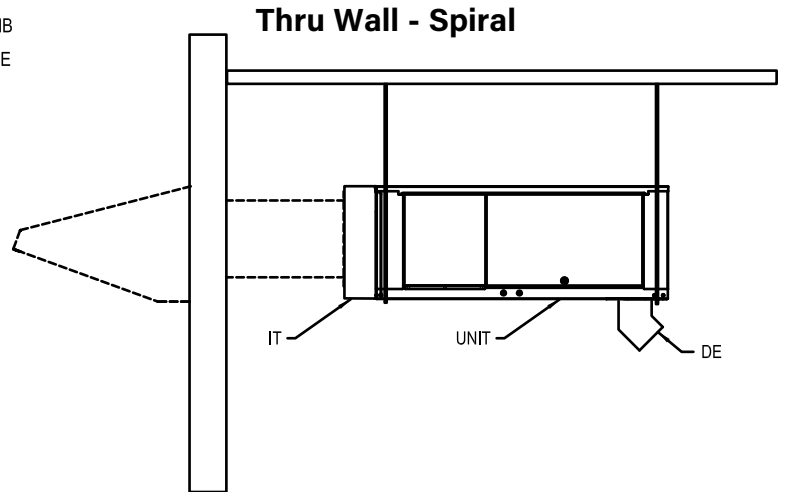
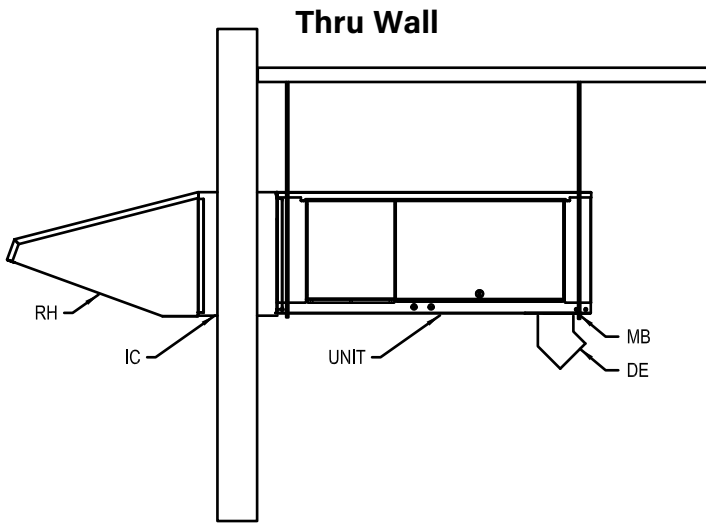

DD	Discharge Duct: The 50" discharge duct for roof top mounting package extends through the mounting curb.
DE	Directional Elbows¹: Used to optimize heat distribution by directing air to meet the requirements of specific field applications. Field mounting is required.
EAT	Entering Air Thermostat¹: The EAT automatically turns off the burner when the outdoor temperature approaches the EAT setpoint temperature (45°F to 70°F) while maintaining blower operation for ventilation.
EFC	Exhaust Fan Contact: The EFC is an auxiliary dry contact mechanically interlocked to the operation of the motor starter of the heater. The dry contact is typically wired into an exhaust fan control circuit to activate an exhaust fan.
EDL	EDL - Space Heating Gas Trains¹: An electronic discharge air temperature control which utilizes a discharge temperature sensor in conjunction with an electronic proportioning gas valve for maintaining the selected discharge air temperature. This control will permit manual adjustment of the discharge air temperature from 110°F to 160°F via the selector on the amplifier located in the heater's electrical control enclosure.
IC	Inlet Collar: Insulated collar to connect rain hood to unit. Can accommodate up to 21" thick walls.
IT	Inlet Transition: Insulated collar to connect spiral duct to unit.
LFS	Low Fire Start¹: The LFS function limits the initial heater firing for the first fifteen seconds of a heating cycle.
LTC	Low Temperature Cutout with Alarm¹: The LTC alarm circuit functions to shut down the blower in approximately four (4) minutes if either of the following occurs: (1) The inlet temperature drops below the LTC setpoint (40, 45, 50 or 55°F) in the Ventilation mode; or (2) The gas valve fails to remain energized during a heating cycle.
MB	Mounting Brackets: Provided for installation from hanging rods.
MC	Mounting Curb: The insulated 24" mounting curb supports the discharge end of the unit. This mounting curb is designed for conventional, flat roof applications. Counterflashing is included. A cant, if required, is provided by others.
AMS	Mounting Stand: An adjustable mounting stand (18¾" to 26¼") is used as the rear heater support on the roof top mounting package. A cant, if required, is provided by others. A 1½" thick piece of pressure treated wood is required (not provided) for the base of the stand to rest on to meet the overall height of 24".
PT	Pre-Purge Timer¹: The PT function provides a minimum of four air changes in the heater housing and any attached inlet accessories or field installed ductwork prior to an ignition attempt. The time is selectable at 2, 4, 8, 16, or 32 seconds.
RH	Rain Hood: Provided with a metal inlet screen.
SS	Service Switches¹: Located in the heater to allow local control by Service Technician when servicing the heater.

¹ Included with all units.

Unit Weights and Dimensions

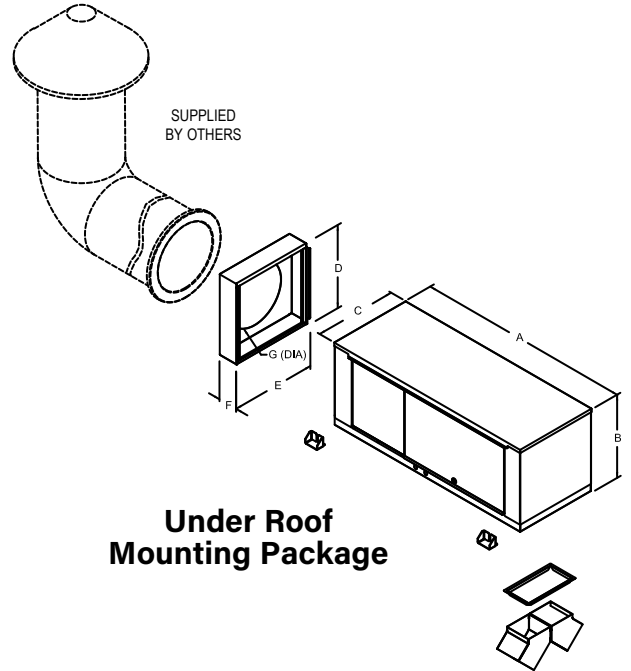
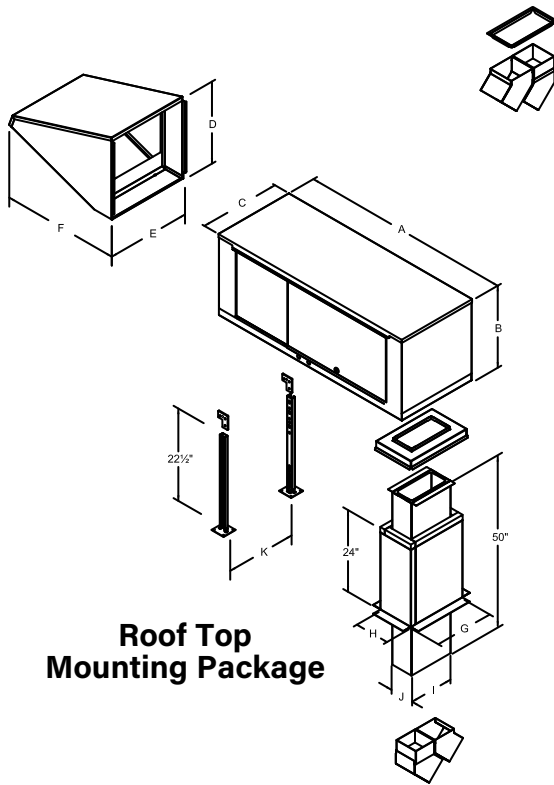
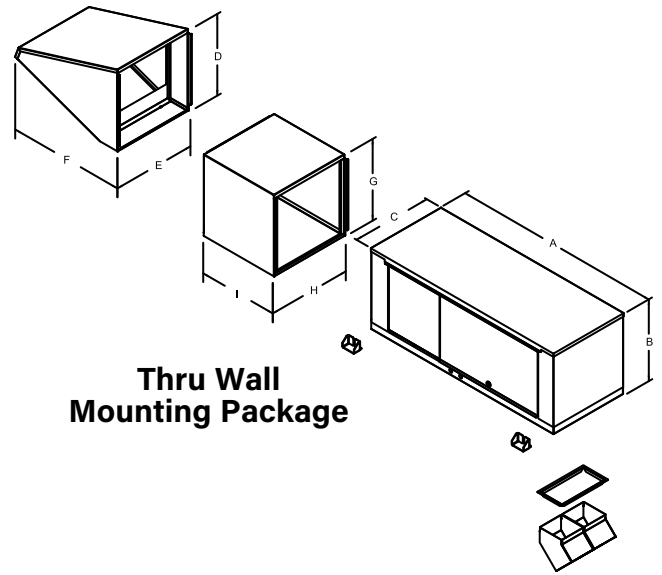
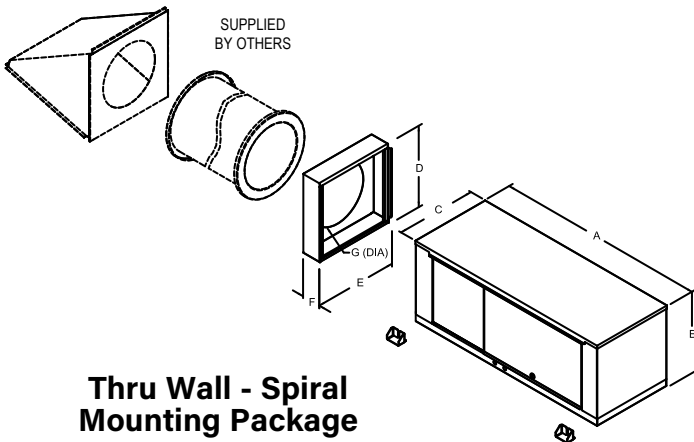

Model	Mounting Package	Dimensions										Weight (lbs.)		
		A	B	C	D	E	F	G	H	I	J		K	
SA250	Roof Top	55"	24 1/4"	21"	21"	21"	30 1/2"	17 1/4"	10"	13 1/4"	6 1/2"	24 1/2"	265	
	Thru Wall						21"	21"	21"				230	
	Thru Wall - Spiral						5"	16"						200
	Under Roof													

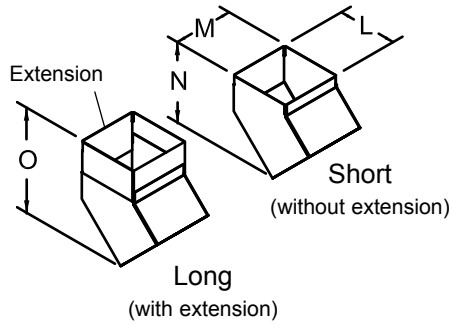

Directional Elbows

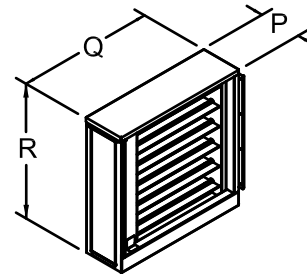

Inlet Damper (optional)

Model	Directional Elbows				Inlet Damper			Weight (lbs.)
	Dimensions				Dimensions			
	L	M	N	O	P	Q	R	
SA250	6½"	6½"	9¾"	12½"	(Internal)			10

S-Series Selection

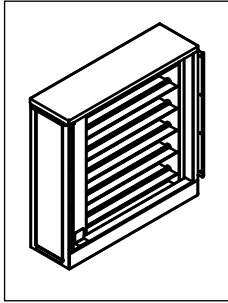

Motorized Inlet Damper (MID)

A two-position damper assembly that closes when the blower is not operating.

Electrical Control Options

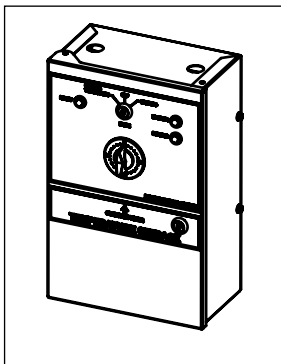

CE-Smart System

A lockable NEMA 1 enclosure (9"w x 14"h x 5"d) equipped with a three position keylock selector switch (Summer Ventilation - Off - Heating), a combination operating electronic thermostat and seven day programmable time clock (TSS), an override timer and indicating lights for blower operation (green), burner operation (red) and reset (amber). The TSS accommodates separate programming for summer ventilation and heating modes.

The operator can control the heater from this panel provided the heater mounted disconnect is in the "ON" position and the service switches are in the "REMOTE" position. The TSS utilizes an encapsulated thermistor to sense space temperature. The adjustable differential is set by the selection of the ON and OFF temperatures. This control can accommodate separately programmed schedules for both the ventilation and heating modes.

An intermittent/continuous control allows the heater to be operated continuously at modulating discharge temperature for make-up air (EDSM - Continuous Make-Up Air Mode) during occupied hours and operated intermittently based on a thermostat at maximum discharge temperature (EDL - Space Heating Mode) for space heating during unoccupied hours.

Terminals are provided for wiring of an exhaust fan interlock (EFI) contacts provided by others. Typically used when the heater shall come on when an exhaust fan comes on.

High Pressure Regulator (HPR)

A positive shut-off high pressure regulator is required when the gas supply pressure exceeds the maximum gas pressure requirements or is specified by local codes or utilities. It is sized according to the gas supply pressure and the capacity requirements of the heater. It must be vented to the outdoors. (Specify gas supply pressure.)

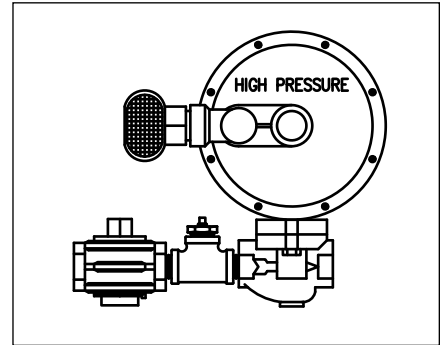

Summary of Limited Warranty

Cambridge Air Solutions warrants all SA-Series products, including all components and sub-components thereof, to be free from defects in material and workmanship for a period of **twenty-four (24) months** from date of shipment, with the exception of the burner which is warranted for **five (5) years**, provided the product is properly installed and operated under normal conditions in accordance with the Cambridge Technical Manual and any other applicable instructions and in conformance with national and local codes.

***For complete warranty, see Standard Terms and Conditions
in the product catalog or the Technical Manual.***

Wiring Diagram

For SA250 only

(Refer to Tech Manual for other options)

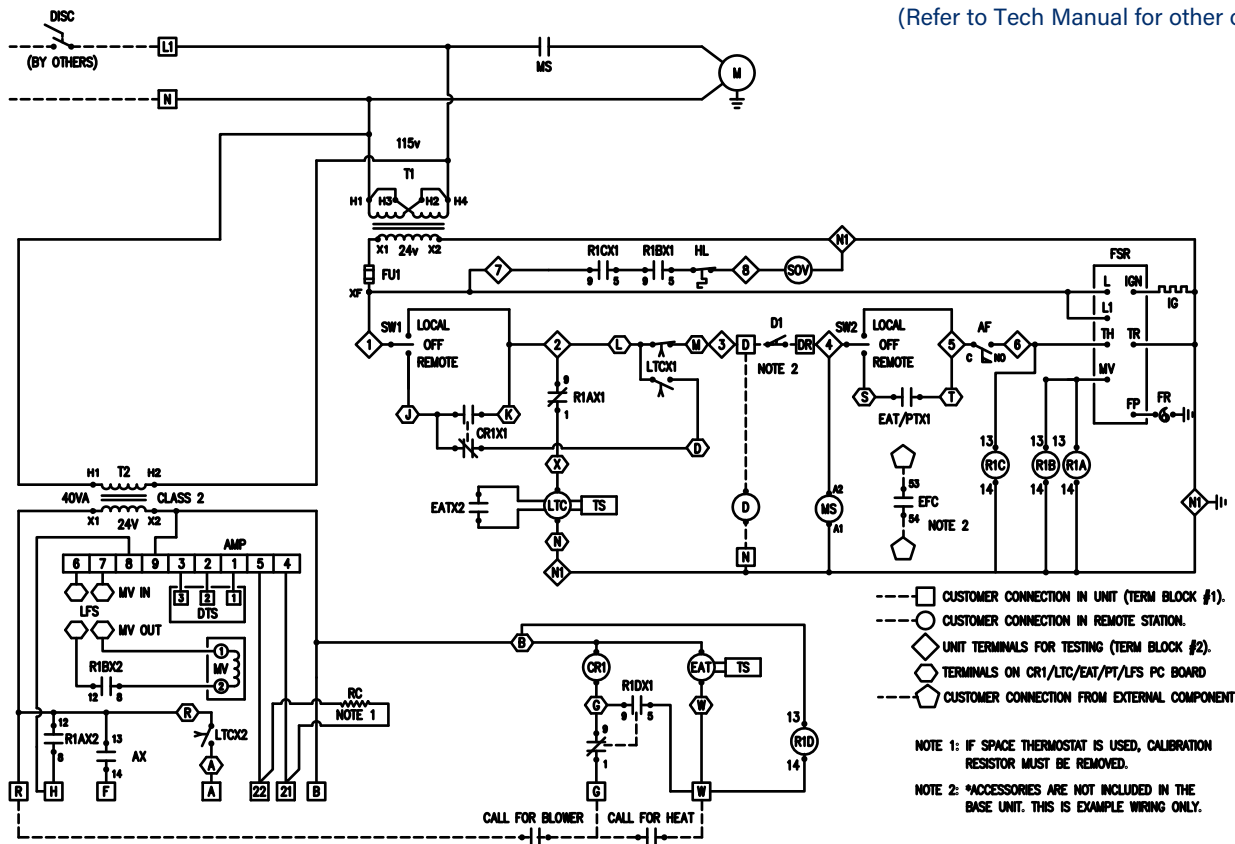

Symbol	Description
AF	Air Flow Switch
AMP	Amplifier Solid State
AX	Auxiliary Contact
CR1	Control Relay
D & D1	Damper Motor & End Switch
DTS	Discharge Temperature Sensor
EAT	Entering Air Thermostat
EFC	Exhaust Fan Contact
FR	Flame Rod
FSR	Flame Safeguard Relay (HSI)

Symbol	Description
FU1	Fuse 24 Volt Control
HL	High Limit
IG	Igniter
LFS	Low Fire Start
LTC	Low Temperature Cutout
M	Motor
MS	Motor Starter
MV	Modulating Valve
PCB	Printed Circuit Board
PT	Purge Timer

Symbol	Description
R1A,B,C	Relays - Gas Valve
RID	Relay - Thermostat Control
RC	Resistor - Calibration
SOV	Shut-Off Valve - Gas
SW1	Service Switch - Fan
SW2	Service Switch - Heat
T1	Multi-Tap Transformer (24 & 120 Volt)
T2	Class 2 Transformer (24 Volt)
TS	Temperature Sensor (LTC/EAT)

Model	Motor HP	Heater Amperage Requirements		
		115V/1Ph	208V/1Ph	230V/1Ph
SA250	3/4	12.3		